



Safe Use and Handling of Diisocyanates

Distribution / Bulk Liquid Transport
Loading / unloading Trucks

Disclaimer



The present training material has been developed by ISOPA in close partnership with other representatives of the diisocyanates value chain with the aim to enhance safety awareness and improve the conditions for safe use of diisocyanates.

The training does not replace the instructions for use supplied with the products nor does it replace medical advice or environmental guidance. Should there be a discrepancy between workplace instructions and what you learn in this training, you are encouraged to discuss this with your supervisor.

While ISOPA make every effort to present accurate and reliable information in utmost good faith on the basis of the best information currently available, they are aware that diisocyanates are used by a wide range of industrial and professional users, for a multitude of applications and in a variety of circumstances. Accordingly, this training material is meant to enhance awareness for safe use that must be adapted to the specific circumstances of any given case. No representations or warranties are made with regard to the completeness, accuracy or reliability of the training materials. Any industrial and professional user should be aware that diisocyanates are chemical substances whose use requires appropriate expertise and respect of applicable safety precautions, and the use of diisocyanates may have effects on the personal health or the environment. No liability will be accepted by ISOPA or any company participating in ISOPA for any injuries sustained when using diisocyanates.

ISOPA encourage all industrial and professional users to be vigilant, to follow the guidance and instructions provided by the producers, suppliers, distributors, employers, instructors, public authorities and other relevant bodies and organisations, and carry out their own assessment of the safest use of diisocyanates in their individual circumstances.

ISOPA is the European trade association that represent the manufacturers of aromatic diisocyanates and polyols in Europe.

Further information on ISOPA can be found at <https://www.isopa.org/>.

Know the risks
Work in a safe environment
Protect yourself and others



What are diisocyanates?



DIISOCYANATES

AN AMAZING VERSATILE CHEMICAL BUILDING

ISOPA
EUROPEAN ISOCYANATE & POLYOL
PRODUCTION ASSOCIATION

ALIPA
ALIPHATIC ISOCYANATE PRODUCTION ASSOCIATION

Play Video

Diisocyanates are a family of chemical building blocks used to make polyurethanes or polyurea materials like:

- foams
- thermoplastic and elastomers
- paints and inks
- adhesives, coatings and sealants
- composite wood products

Why this Training?



Diisocyanates are pivotal for the production of Polyurethanes (PU).

Diisocyanates are hazardous substances and require therefore training to ensure safe handling of these chemicals.

Because Diisocyanates may trigger adverse health effects at low concentrations, tailored safe handling training is mandatory.

The main concern is the sensitization of the respiratory tract, which may lead to occupational asthma.





Are diisocyanates safe?

- All diisocyanates are hazardous and have a potential to contribute to occupational asthma,
- Hence they have to be handled with care.

Safe Use

- The use of diisocyanates is safe when they are handled according to relevant risk management and safety measures.
- After diisocyanates are completely reacted with other chemicals and transformed into finished goods, risks of exposure disappear.



1

Background







- MDI / TDI can be handled safely and are in widespread use across the world.
- This programme helps in the safe transport of these chemicals by ensuring proper training of drivers
- The training package is a joint effort of ISOPA and the carriers based on practical experience.
- Drivers who successfully complete the driver training are issued with a MDI / TDI Driver Training Certificate



Physical and Chemical Properties



Appearance

	Liquid	Reacted
Polymeric MDI	Clear to brown Slightly musty 	Brown Crusty 
Monomeric MDI * TDI	Clear to pale yellow Sharp, pungent 	White Foamy 

* Monomeric MDI is liquid when heated above 38 °C

OEL – Occupational Exposure Limit Value

OEL is a regulatory value which indicate levels of exposure that are considered to be safe in the air of a workplace. For both MDI and TDI this value is in average 5ppb*

Odor threshold is very personal and not officially reported.

- In one study a panel of volunteers recognized the odor
- of TDI at 50 ppb.

Therefore:

- When you smell it, it's above the limit !
- Do not store used PPE in your cabin

* might differ from country to country



Main physical and Chemical Properties

Vapour pressure:

- Dangers of MDI and TDI are of the same magnitude but
- vapour pressure of TDI is much higher (20x),
- therefore the RISKS of TDI are much higher

Vapour density = 6× Air density

- I. e. the vapours are heavier than air !

Density range 1.20 – 1.29 (1.2x heavier than water)
(For TDI filling degree conform ADR)

Important **temperatures (TDI):**

- Crystallization starts at $\pm 15^{\circ}\text{C}$ (product temp.)
- Melting when reheated to $\pm 45^{\circ}\text{C}$ (product temp.)



**Polymeric
MDI**



**Monomeric MDI
TDI**

Degree of Filling for TDI

ADR 4.3.2.2 Degree of filling

4.3.2.2.4

"Where shells are not divided by partitions or surge plates into sections of not more than 7,500 litres capacity, they shall be filled to not less than 80% or not more than 20% of their capacity".

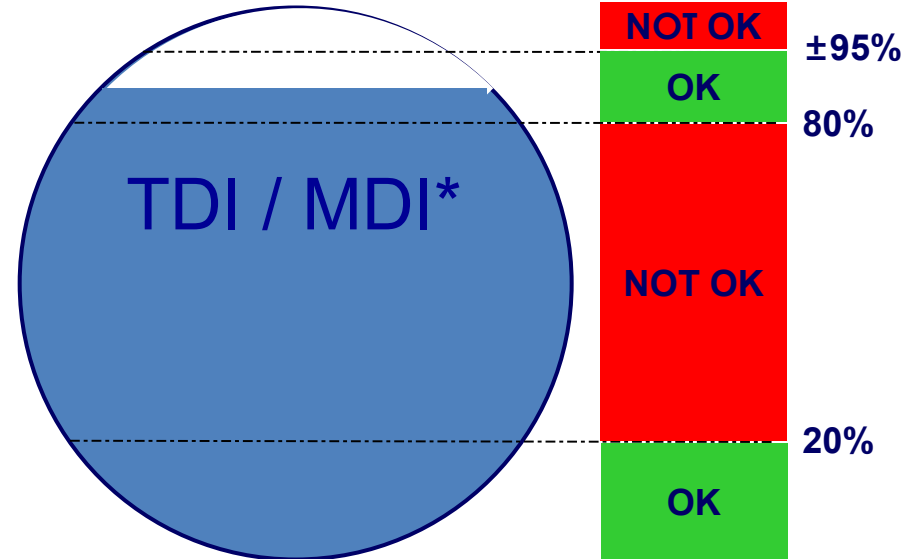

*) For MDI there is no legal requirement but all producers follow the same rules as for TDI

**Odour is not a
reliable indicator
for hazard**

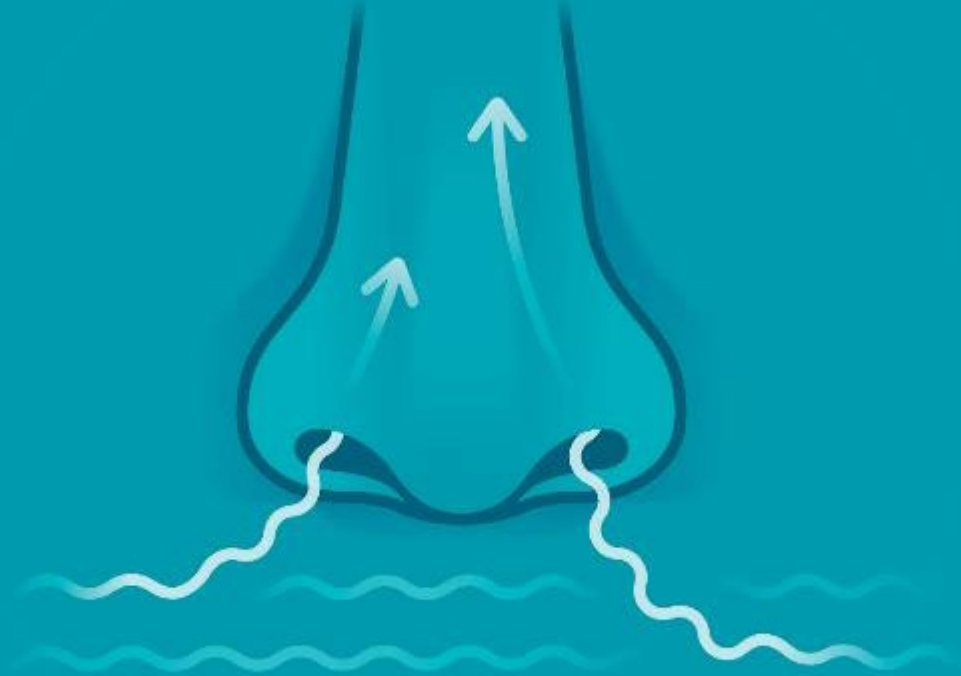

Odour as indication of hazard

- At the maximum allowable workplace exposure levels, diisocyanates cannot be detected by most people.
- However if you can not smell it, it does not mean it is not hazardous.
- Odour should never be relied upon as an indication of exposure diisocyanate.



What does Sensitization mean

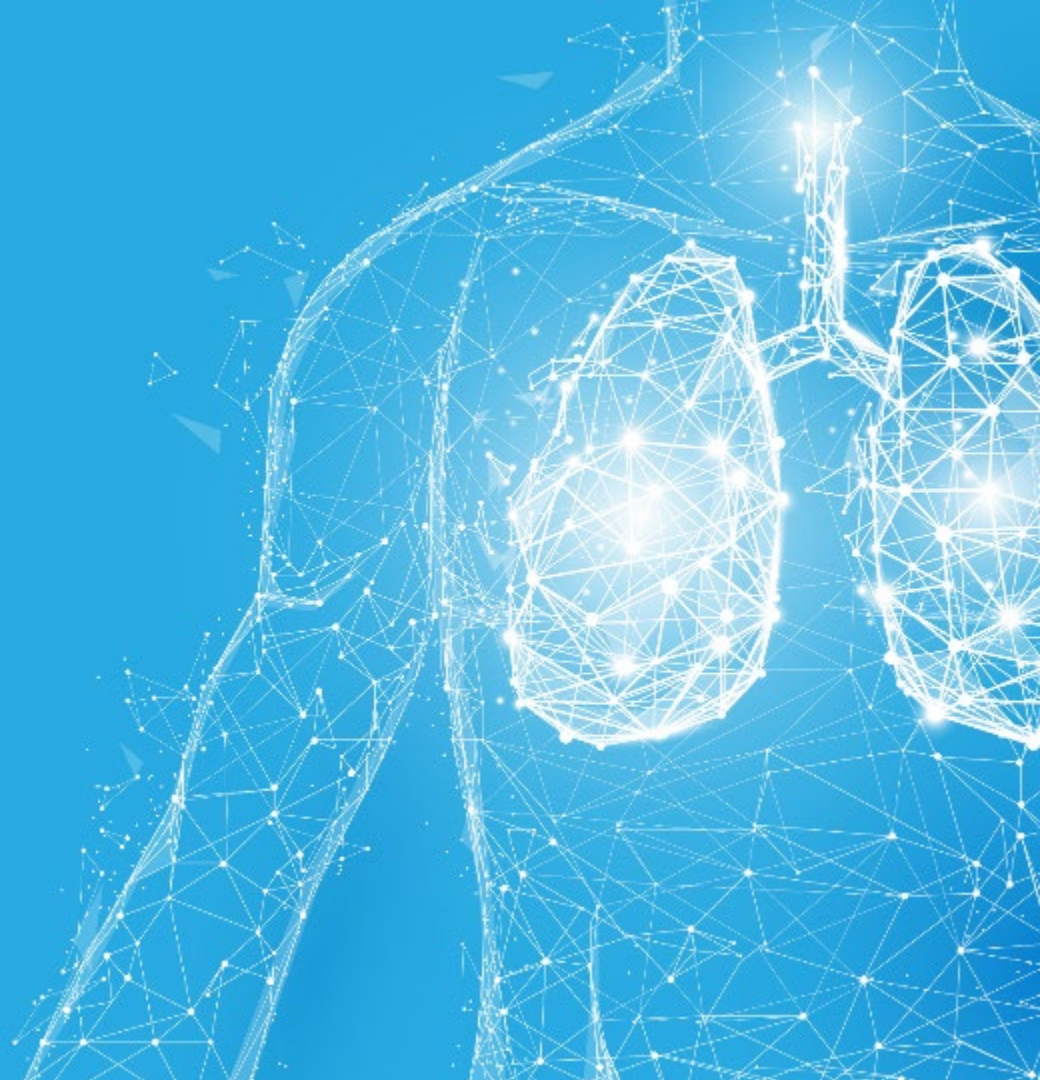

How can Diisocyanates harm you?

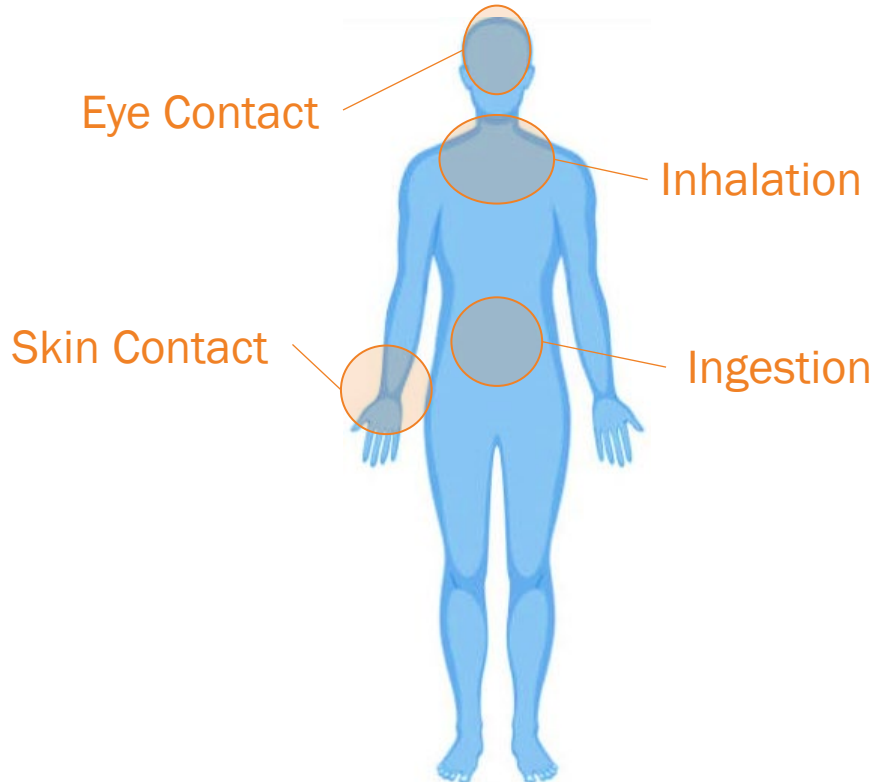

- By splashes into your eyes
- By inhaling vapours, aerosols (fine droplets) or dust
- By swallowing if you eat after handling chemicals, without washing hands first
- If liquid touches your skin and by contact with contaminated surfaces

There can be no health impact if Diisocyanates are prevented from entering your body with the right Risk Management Measures.

Effects of Diisocyanates on your Health

Short term/one-off exposure above safe level, potentially:

- Irritates mouth, throat, lungs
- Tight chest, coughing
- Difficulty in breathing
- Eyes watering
- Itching, red skin (immediately or delayed)
- May be hot or burn skin

Symptoms can occur several hours after exposure

A lot depends on the level of exposure and the sensitivity of the person



© 2017 John Wiley & Sons A/S. Published by John Wiley & Sons Ltd

Effects of Diisocyanates on your Health



Long term/repeated over-exposure from breathing or skin contact leads to risk of sensitization

- Symptoms such as occasional breathing difficulties can be compared to hay fever symptoms.
- When sensitized, severe asthma potentially occurs even in the case of low diisocyanate exposure.

Sensitization could prevent working with Diisocyanates for life; early and prompt removal from exposure can typically result in cessation of allergic responses.

**Sensitization is non-reversible and is a reaction of the immune system.
Not to be confused with irritation.**

Why Hazard Communication?

- To ensure that you are informed on the hazards of workplace chemicals.
- Know how to protect yourself with the recommended protective measures.
- Tools for Hazard Communication are:

Product Labels



Safety Data Sheets (SDS)

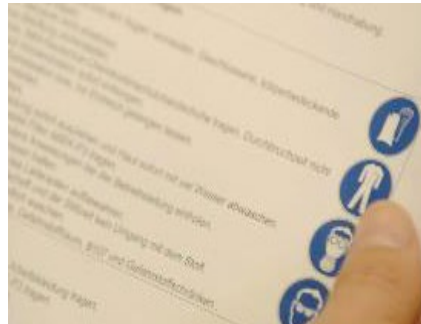

Operating Instructions Awareness Training



What is a Hazard Label?

- Hazard labels can help you to:
 - identify hazardous chemicals
 - know what the hazards are and how to avoid them
- Make sure you read the instructions to ensure safe use

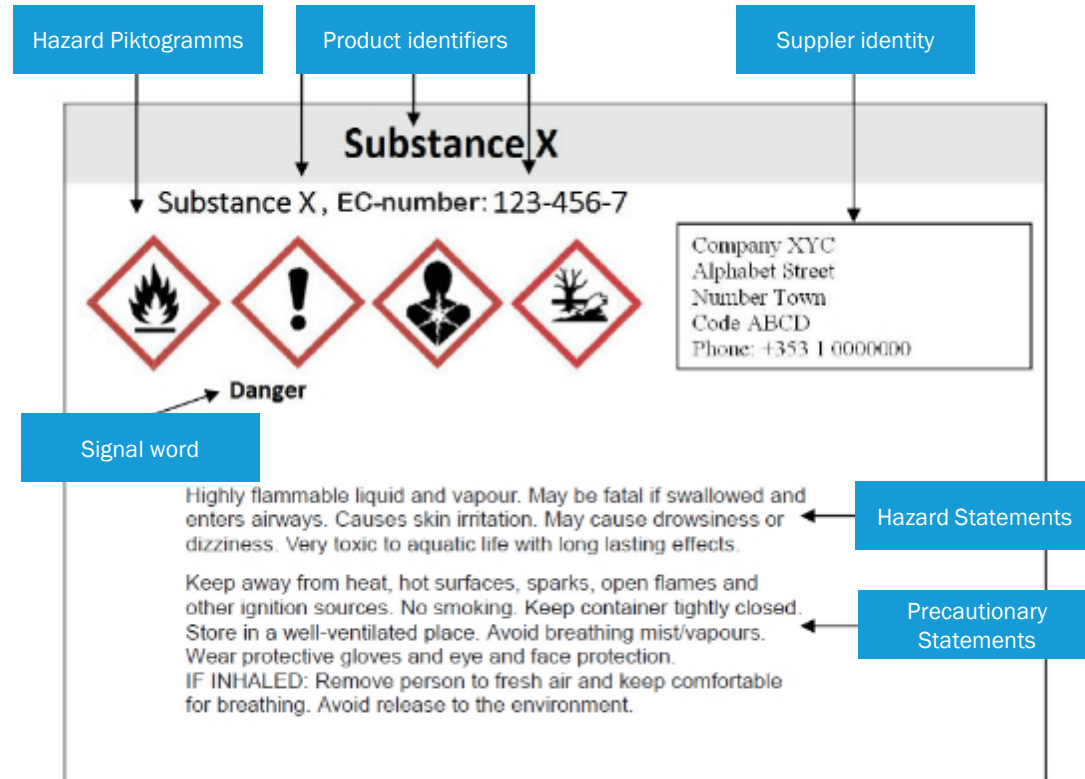

What is a Safety Data Sheet (SDS)?

- The SDS is a key document in the safe supply, handling and use of hazardous chemicals.
- The SDS provides the necessary information to help to protect human health and the environment.
- Make sure you read and understand the SDS content.

SDS Sections	SDS Introduction
Section 1, 2 & 3	Chemical & Hazard Identification, Composition
Section 4, 5 & 6	First aid, Firefighting & Accidental release measures
Section 7	Handling & Storage
Section 8	Exposure Controls & Personal Protection
Section 9	Physical & Chemical Properties
Section 10	Stability and Reactivity
Section 11 & 12	Toxicological and Ecological information
Section 13	Disposal, Diisocyanates & empty containers
Section 10-12, 14-16	Transport, regulatory and other information

More
Information
about SDS



Emergency Number
in Section 1 of SDS

Health Hazards of Diisocyanates

All Diisocyanates are hazardous. They are known as....

- Skin irritants and sensitizer
- Eye irritants
- Respiratory sensitisers
- Some Diisocyanates are fatal if inhaled

The health are represented by the Hazard (H) statements and pictograms on the Safety Data Sheets and labels

- A skin irritant is a chemical which, in case of skin contact, can create dermatitis, a disease of the skin.
- An eye irritant is a chemical which in case of eye contact, can irritate the eyes.
- A respiratory sensitizer is a chemical which when inhaled can trigger an irreversible allergic reaction in the respiratory system.



Health Hazard



Serious Health Hazard



Acute Toxicity

Product Hazards for (un)loading operation

MDI

Harmful



- Irritating to eyes, respiratory system and skin
- Risk of sensitization by inhalation and skin contact

Warning:





- This effect can be delayed for as long as **24 hours after exposure!**
- Sensitisation means build up of **irreversible** allergic reactions

TDI

Very toxic by inhalation



Classification & Labelling / placarding

Product	Transport	Use & Storage
MDI	Not regulated but still harmful	 
TDI	<p>ADR / RID / IMDG HI 60 (Hazard Identification Number) UN 2078 Class 6.1 Packing Group II Marking and Labelling: ADR tunnel Restriction code: (D/E)</p>	 

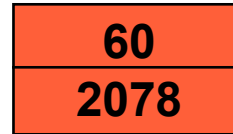



6

Personal Protective Equipment (PPE)



Personal Protective Equipment

See what you must consider about
Personal Protective Equipment



Play Video

MDI safe Handling

If there is a risk of eye and skin contact with Diisocyanates always wear:

- Safety glasses or goggles
- Diisocyanates resistant gloves: neoprene or nitrile
- Lab coat or coverall, long trousers
- Closed shoes
- Eye wash bottle



If there is potential for more extensive exposure, use following:

- A hard hat
- Diisocyanates resistant long-sleeve coveralls or full body suit
- Diisocyanates resistant fitted boots
- Full face mask (with appropriate filter – min AP2)
- Also consider respiratory protection

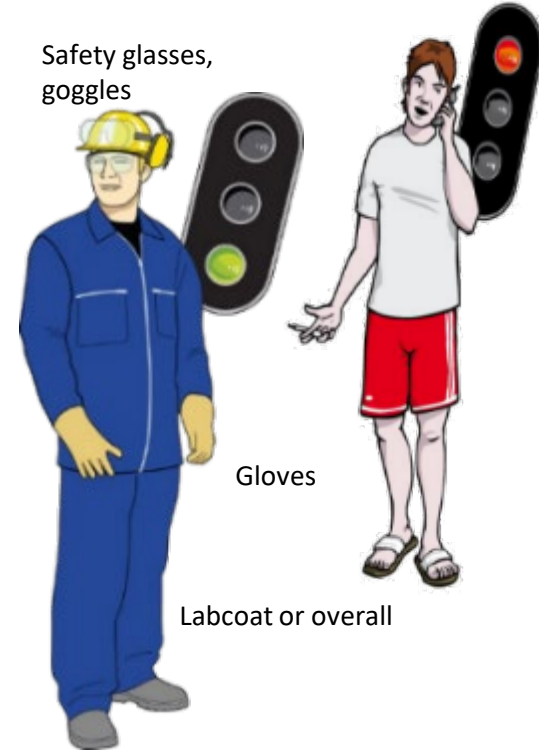

For TDI only

- Use an appropriate cartridge / canister (min. AP₂)
- For normal use, once opened, use max 8 hours within any 48 hours time span if no contamination
- After any spill change the cartridge
- Face mask should not be used for Emergency Response
- Eye wash bottle



Diisocyanates Safe Handling

- Check gloves are intact
- Always use the correct size of gloves
- Replace gloves immediately if contaminated
- Remove carefully to protect your skin from contamination
- Don't use latex gloves
 - They are permeable to a number of chemicals
 - Risk for creating a latex allergy



- Neoprene
- Nitrile rubber

Diisocyanates safe Handling - Ventilation

- Overexposure to Diisocyanates can occur in not adequately ventilated environments and when:
 - Diisocyanates are sprayed/aerosolized
 - Diisocyanates are heated
 - Very volatile Diisocyanates are used (e. g. pure HDI or TDI)
 - Dust containing unreacted Diisocyanates
 - to reduce the risk, Respiratory Protective Equipment (RPE) either air-supplied or air-purifying is required
- Advice on RPE in SDS\Section 8
- RPE is covered by additional regulations in many countries

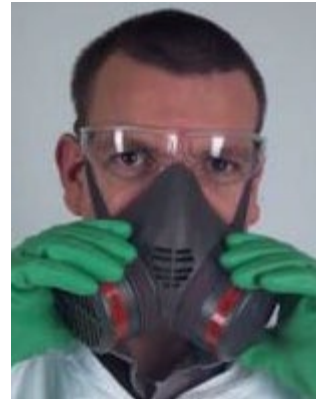



7

Personal and Industrial Hygiene



Personal Hygiene

- Wash your hands after finishing work and before eating, drinking or smoking
- Never use solvents to clean your skin
- After working with diisocyanates change cloths
- Do not reuse contaminated clothing or gloves
- Change clothing regularly
- Apply hand cream to protect the skin against drying



Industrial Hygiene Basics

When working with diisocyanates **always**:

- Avoid inhalation of vapour
- Avoid dermal contact
- Avoid contact of the eyes with diisocyanates

- Do no drink, eat or smoke at the working place
- Make sure that the working place is well ventilated
- Always wear the appropriate Personal Protective Equipment and keep it well maintained

- Train your local emergency protocols
- Keep your working place clean and tidy

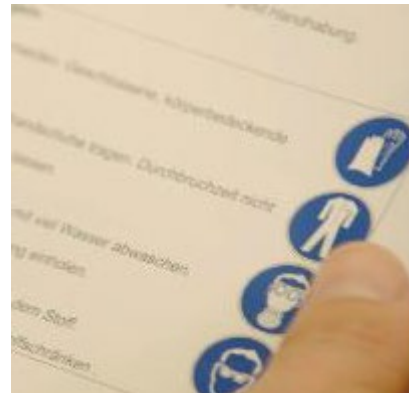



8

Product Quality Acceptance



Product Quality Acceptance

- Certificate of Analysis (CoA)
- Samples
 - Driver is not allowed to take samples
 - CoA is strongly preferred to a sample
 - Sampling is not representative for the full tank container
 - **Never** transport a sample in your cab
- Temperature (Customer specific)



Emergency Situation



First Aid for Diisocyanates

See what what needs to be done
in case of an emergency



Play Video

First Aid for Diisocyanates

Eye contact exposure:

- Force open the eyelids
- Flush with lots of water for at least 15 minutes
- If in doubt, keep flushing
- See eye specialist as soon as possible
- Advice not to wear contact lenses

Skin contact exposure:

- Immediately remove contaminated clothing
- Wash off thoroughly with large amounts of water and then wash well with soap and water

Inhalation exposure:

- Move from risk of further exposure to an area with fresh air
- Contact supplier – who can provide supporting information

You should not use contact lenses when handling isocyanates

If symptoms develop, obtain medical attention



Site Safety

Make yourself familiar with the site emergency policy and location of following items:

- Signs & Alarms
- Wind direction indicator
- Emergency stop button
- Emergency shower
- Assembly point
- Waste bin (for used gaskets, gloves, etc.)
- Decontamination & Absorption material



First Aid Equipment



- Know where your first aid equipment is
- Know what to do
- Know whom to tell
- Emergency Shower
- Clean running water is best
- Eyebath or eye wash bottle
- Call a doctor

... and don't panic !

Handling a Diisocyanate Spillage

Be aware your PPE is not suitable enough in case of any emergency !!

- Drivers should observe from a safe distance and remain available to provide information
- Always contact your company planner in case of an incident
- Emergency Response services with the right PPE should:
 1. Cover sewer system
 2. Absorb the spill
 3. **Wait** (15 minutes)
 4. Neutralise
 5. **Wait** (30–60 minutes after reaction has finished)
 6. Remove spill after reaction has finished.
 7. Put residues in designated chemicals waste bin
 8. Apply decontamination fluid





10

(un)loading Specific



Prevent Falling from Heights - Fall protection (1)

- During unloading of TDI / MDI, you will have to work on top of your road tanker or tank container
- A US study shows that 1 in 5 driver injuries related to falling from heights and 1 in 1,000 of these injuries results in a fatality
- For TDI / MDI, a single collapsible handrail is not considered as adequate fall protection and is considered as hazardous
- The best solution is a fixed gantry or cage (top) with 360° guard rails while a mobile platform provides a cheaper and more flexible alternative (bottom picture)



Prevent Falling from Heights - Fall protection (2)

If a gantry or cage is not available, the use of a fall arrest harness is an acceptable alternative.

Ensure that:

- You always have your inspected & well maintained harness with you
- You inspect it for defects and damage before each use
- You are trained on how to wear your harness
- The site provides a connection point (preferably sliding or mobile)
- and a lanyard (preferably with a self-lowering fall arrest line)
- The site operator confirms that the site you are visiting has a rescue plan in place that will ensure a fast recovery in order to avoid suspension trauma and is present during operation.



Tank Equipment

- Manlid must be kept closed! (moisture prevention)
- Ensure customs letter (if applicable) is present
- Do not mix-up the vapor return and liquid line !!!
- Tank depressurized?
- Cleaned tanks must be dry !
- Capacity (keep filling degree in mind!)



3-Minutes Check before Loading

Equipment

- Tanker exterior clean?
- Spillage tray clean?
- Tanker correctly labelled and placarded?
- All valves closed, blind flanges/caps in place?
- Manlid closed and bolts tightened?
- Check temperature



Use checklist

3-Minutes Check after Loading

Equipment

- Disconnected?
- Free of spillages including spillage tray?
- Safety handrail down?
- Valves closed, blind-flanged and new gasket?
- Only slight overpressure (max 0.2 bar)?
- Temperature setting correct?

Documentation

- Transport document, Customs letter, CoA, Weight ticket, DGD?
- Instructions in writing?



Use checklist

Opening of Tanks in Transit by Customs Officials



- Tanks should not be opened whilst in transit because of the dangers to human health
- ISOPA issued a letter to Customs Officials explaining the reasons why
- Letter is available in 14 languages i.e.
CZ - DE - EN - ES - FR - HU - IT - LV - PL - RO - RU - SK - TUR - UA
- Letter can be downloaded from the ISOPA website
<https://www.isopa.org/documentation/>

Transport

- Hours / Speed
- Check temperature (and pressure)
- Reporting unsafe conditions / incidents
- Parking
 - Do not leave the vehicle unlocked
 - Do not disclose information about product carried, customer, route or destination
 - Park preferably on secure parking areas



Heating

All methods:

- Maximum product contact temperature = 60 °C
- Do-not-open-the-manlid

Steam:

- Only external steam coils
- Maximum 1.7 bar (= ~ 115 °C)

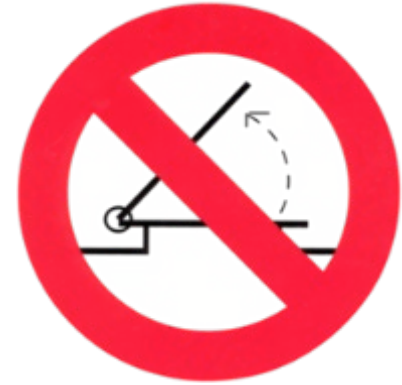

Unloading : Key Points

- Follow site regulations
- PPE must be worn
- Behaviour > You are the supplier's representative
- Know the operational responsibilities between operator and driver
- Storage tank capacity -> Communication driver / operator
- Observe connections, pressure during unloading
- Unloading methods (Details on next slides)
- Report unsafe conditions, near misses and incidents at customers
- **DO NOT TAKE SAMPLES - in case requested report back**



[This Photo](#) by Unknown Author is licensed under [CC BY-SA](#)

Discharge Methods



Customer liquid pump and vapor return

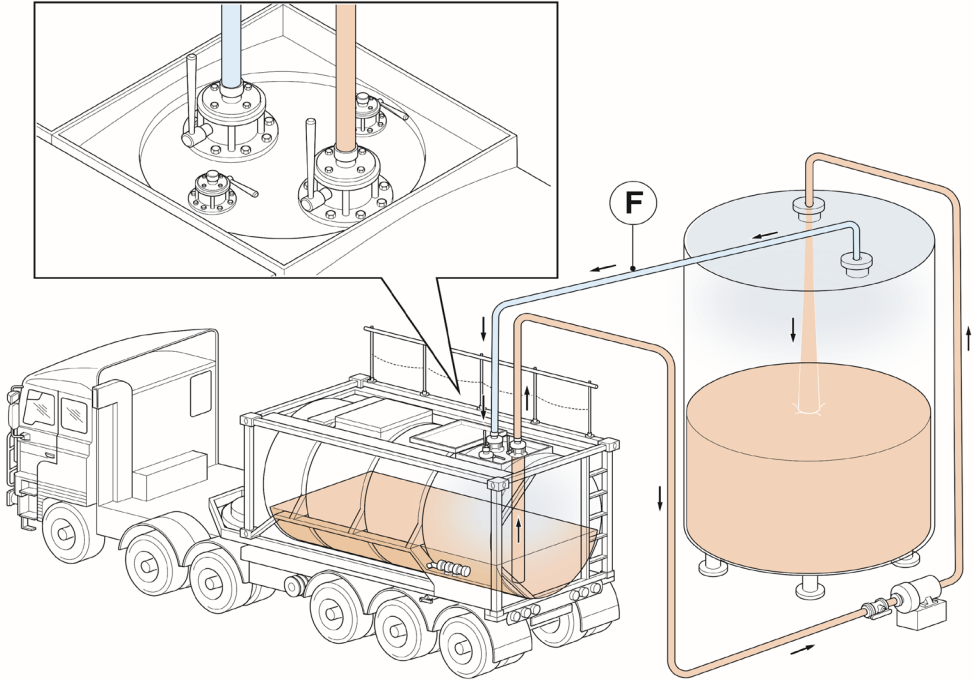

Recommended
according to ISOPA Bulk
Guidelines

Preferred option is a close
system with hoses provided
by customer

Customer nitrogen or dry air

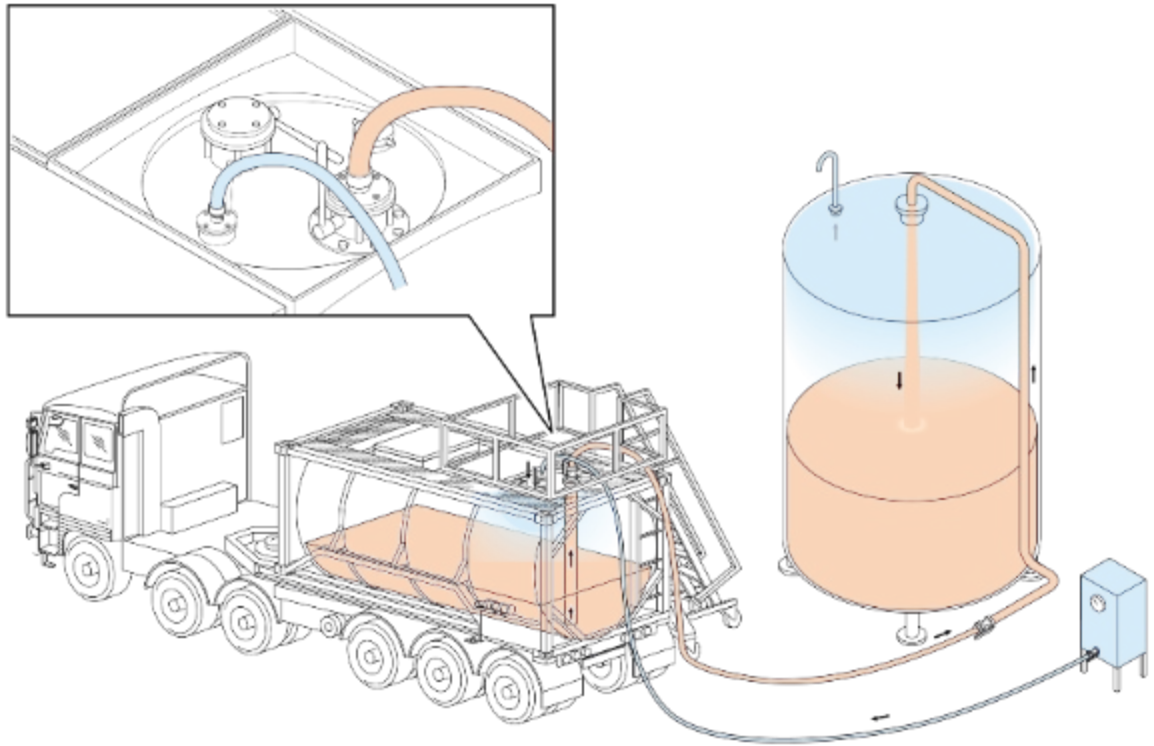

Not In line
With ISOPA
Bulk Guidelines

Vehicle compressor with silica gel

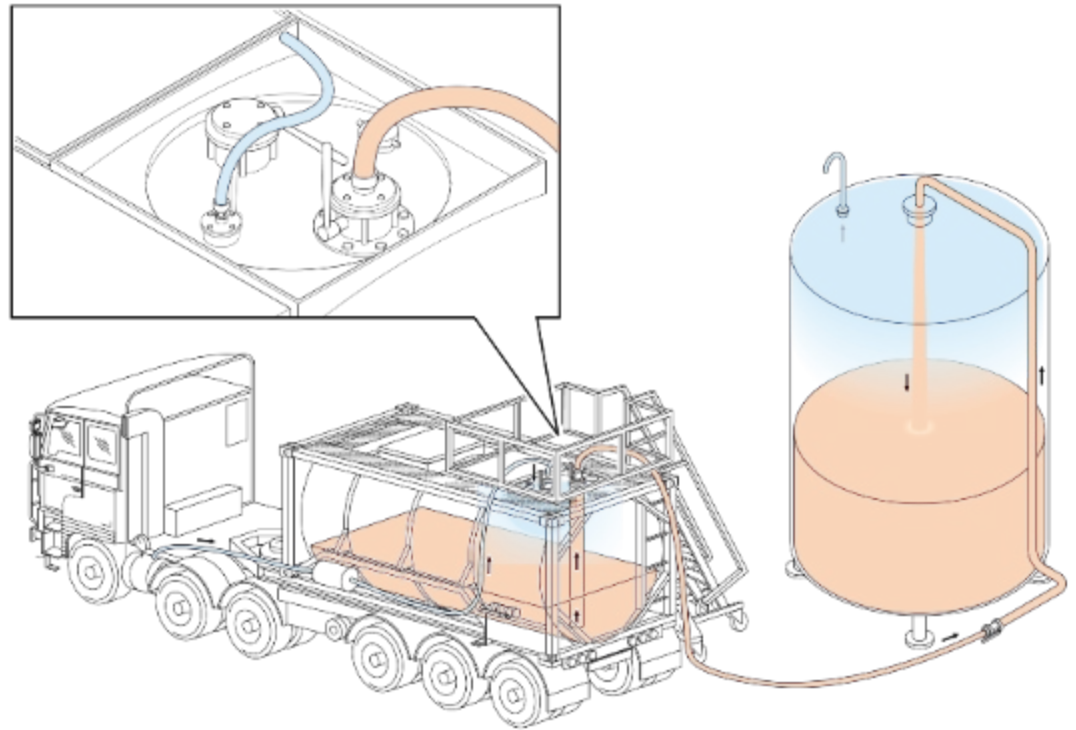

Not In line
With ISOPA
Bulk Guidelines

Vehicle compressor without silica gel

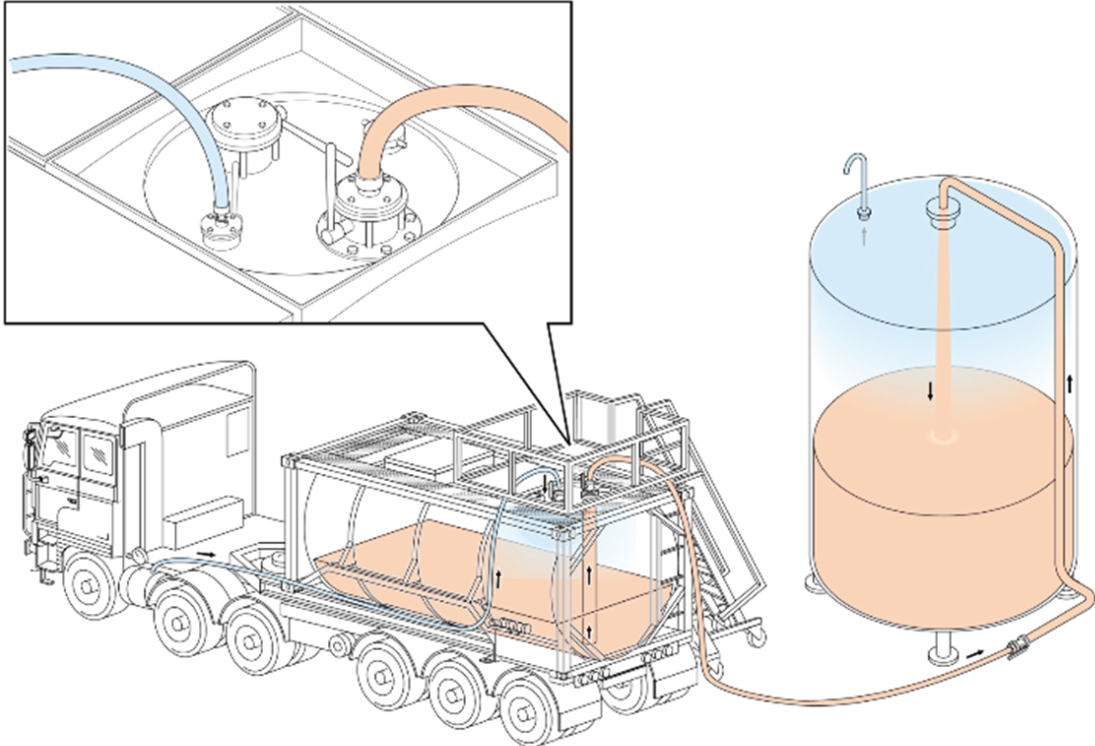

Improvements
Highly recommended

Spillage Tray Lay-out (example)

Liquid line and vapor return line connections should be properly identified

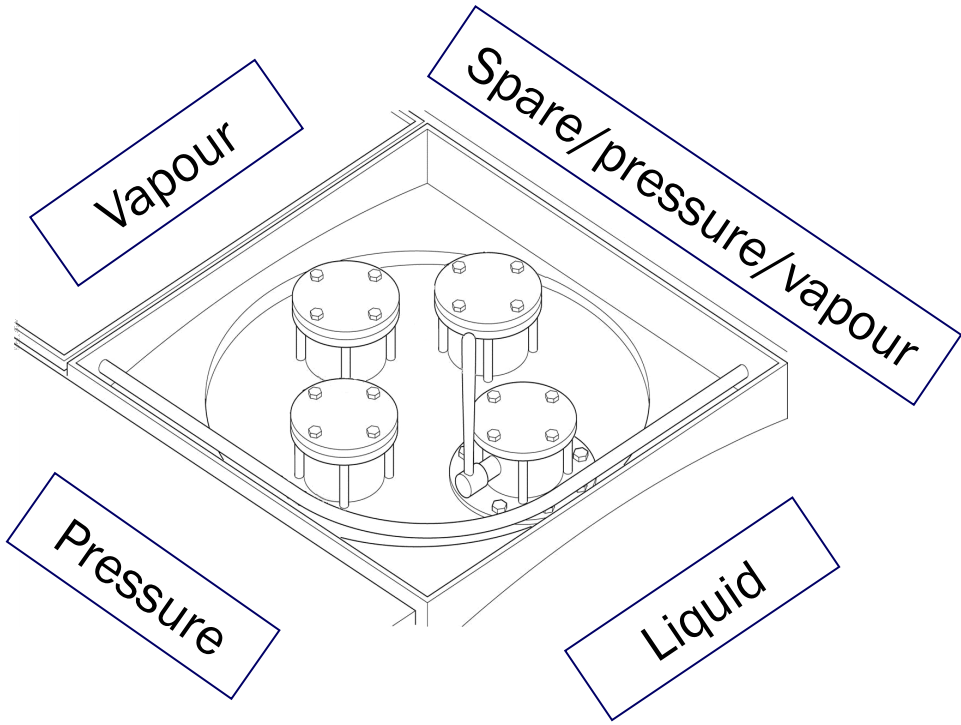

3-Minutes Check after Discharge

Equipment

- Disconnected ?
- Free of spillages including spillage tray ?
- Safety handrail down?
- Valves closed and blind-flanged, manlids closed ?
- Spillage tray covers closed ?
- Only slight overpressure (max 0.2 bar) ?
- Depressurize to max 0,2 bar at the customer if possible, or inform planner



Use checklist

3-Minutes Check after Discharge

Documentation

- Handed to the customer?
 - Copy of transport document signed by driver & customer
 - Certificate of Analysis (if not sent upfront)
- Driver keeps another copy of transport document signed by driver & customer

For TDI: Obtain or make transport document reading:

Empty tank container*, last load: UN 2078 Toluene Diisocyanate, 6.1, II (D/E)

*or: tank vehicle; demountable tank; portable tank

Incident Reporting



Incidents



Statistics indicate:

- More than 80% of all incidents are related to **human behavior**
- Most incidents and accidents occur during loading & unloading

YOU
are our most
important
safety factor

Near misses & unsafe Conditions

Active near miss reporting will reduce / avoid serious incidents:

- Road traffic incidents
- Equipment failures
- Incorrect human behavior
- Overflows
- Overpressure
- Spills
- Unexpected temperature rise (check regularly!)
- Unsafe working conditions (missing safety shower, unsafe access to top bulk equipment, sample taken etc.)
- Unsecure routing

Iceberg Theory

Incidents



Near misses &
Unsafe conditions

Near Miss Reporting



Play Video

Know the risks

Work in a safe environment

Protect yourself and others

- All Diisocyanates have potential hazards
- Safety Data Sheet (SDS) -> Read – Understand – Execute
- Operating instructions -> Read – Understand – Execute
- You can minimize the exposure to these hazards
- Always protect yourself where and when needed
- Always follow technical and organisational measures
- Use your Personal Protective Equipment and take care of it
- Do not do anything which can harm you or others
- Accidents are for 80% behaviour related

Test



<https://passport.events/me>



(c) ISOPA

